

TECHNICAL REPORT



**Electroacoustics – Measurement microphones –
Part 10: Absolute pressure calibration of microphones at low frequencies using
calculable pistonphones**



THIS PUBLICATION IS COPYRIGHT PROTECTED
Copyright © 2022 IEC, Geneva, Switzerland

All rights reserved. Unless otherwise specified, no part of this publication may be reproduced or utilized in any form or by any means, electronic or mechanical, including photocopying and microfilm, without permission in writing from either IEC or IEC's member National Committee in the country of the requester. If you have any questions about IEC copyright or have an enquiry about obtaining additional rights to this publication, please contact the address below or your local IEC member National Committee for further information.

IEC Secretariat
3, rue de Varembe
CH-1211 Geneva 20
Switzerland

Tel.: +41 22 919 02 11
info@iec.ch
www.iec.ch

About the IEC

The International Electrotechnical Commission (IEC) is the leading global organization that prepares and publishes International Standards for all electrical, electronic and related technologies.

About IEC publications

The technical content of IEC publications is kept under constant review by the IEC. Please make sure that you have the latest edition, a corrigendum or an amendment might have been published.

IEC publications search - webstore.iec.ch/advsearchform

The advanced search enables to find IEC publications by a variety of criteria (reference number, text, technical committee, ...). It also gives information on projects, replaced and withdrawn publications.

IEC Just Published - webstore.iec.ch/justpublished

Stay up to date on all new IEC publications. Just Published details all new publications released. Available online and once a month by email.

IEC Customer Service Centre - webstore.iec.ch/csc

If you wish to give us your feedback on this publication or need further assistance, please contact the Customer Service Centre: sales@iec.ch.

IEC Products & Services Portal - products.iec.ch

Discover our powerful search engine and read freely all the publications previews. With a subscription you will always have access to up to date content tailored to your needs.

Electropedia - www.electropedia.org

The world's leading online dictionary on electrotechnology, containing more than 22 300 terminological entries in English and French, with equivalent terms in 19 additional languages. Also known as the International Electrotechnical Vocabulary (IEV) online.

TECHNICAL REPORT



**Electroacoustics – Measurement microphones –
Part 10: Absolute pressure calibration of microphones at low frequencies using
calculable pistonphones**

INTERNATIONAL
ELECTROTECHNICAL
COMMISSION

ICS 17.140.50

ISBN 978-2-8322-4374-9

Warning! Make sure that you obtained this publication from an authorized distributor.

CONTENTS

FOREWORD.....	4
1 Scope.....	6
2 Normative references	6
3 Terms and definitions	6
4 Reference environmental conditions	7
5 Principles of absolute pressure calibration of microphones using a calculable pistonphone.....	7
5.1 General principle	7
5.2 Basic expressions.....	7
5.3 Heat conduction correction	9
5.4 Operating frequency range.....	9
6 General characteristics	9
6.1 The pistonphone	9
6.2 Measuring the piston volume velocity.....	10
6.3 Test signals	10
6.4 Mounting the microphone and pressure-equalizing tube.....	10
6.5 Measuring the output voltages of the microphones.....	10
7 Factors influencing the pressure sensitivity.....	10
7.1 General.....	10
7.2 Polarizing voltage	11
7.3 Shield configuration	11
7.4 Dependence on environmental conditions	11
7.4.1 General	11
7.4.2 Static pressure	11
7.4.3 Temperature.....	11
7.4.4 Humidity	12
7.5 Vibration	12
7.6 Distortion	12
8 Calibration uncertainty components	12
8.1 General.....	12
8.2 Measurements of microphone output voltage	12
8.3 Piston	12
8.3.1 Frequency	12
8.3.2 Measurement of the volume velocity	12
8.4 Acoustic transfer impedance	13
8.4.1 Cavity properties	13
8.4.2 Physical quantities.....	13
8.5 Microphone parameters	13
8.5.1 Front cavity.....	13
8.5.2 Acoustic impedance.....	13
8.5.3 Polarizing voltage	14
8.6 Uncertainty on pressure sensitivity level	14
Annex A (informative) Example designs of pistonphones using laser interferometry	16

Annex B (informative) Measurement uncertainties	18
B.1 General.....	18
B.2 Example of a typical uncertainty analysis	18
B.2.1 General	18
B.2.2 Uncertainty budget	18
B.2.3 Combined and expanded uncertainties	19
Bibliography.....	20
Figure 1 – Equivalent circuit for evaluating the sound pressure over the exposed surface of the diaphragm of the microphone	8
Figure A.1 – Schematic cross-section of a laser pistonphone.....	16
Figure A.2 – Example of laser pistonphone	17
Figure A.3 – Example of laser pistonphone	17
Table 1 – Uncertainty components	14
Table B.1 – Example of uncertainty budget at 1 Hz	19

INTERNATIONAL ELECTROTECHNICAL COMMISSION

**ELECTROACOUSTICS –
MEASUREMENT MICROPHONES –**
**Part 10: Absolute pressure calibration of microphones
at low frequencies using calculable pistonphones**
FOREWORD

- 1) The International Electrotechnical Commission (IEC) is a worldwide organization for standardization comprising all national electrotechnical committees (IEC National Committees). The object of IEC is to promote international co-operation on all questions concerning standardization in the electrical and electronic fields. To this end and in addition to other activities, IEC publishes International Standards, Technical Specifications, Technical Reports, Publicly Available Specifications (PAS) and Guides (hereafter referred to as “IEC Publication(s)”). Their preparation is entrusted to technical committees; any IEC National Committee interested in the subject dealt with may participate in this preparatory work. International, governmental and non-governmental organizations liaising with the IEC also participate in this preparation. IEC collaborates closely with the International Organization for Standardization (ISO) in accordance with conditions determined by agreement between the two organizations.
- 2) The formal decisions or agreements of IEC on technical matters express, as nearly as possible, an international consensus of opinion on the relevant subjects since each technical committee has representation from all interested IEC National Committees.
- 3) IEC Publications have the form of recommendations for international use and are accepted by IEC National Committees in that sense. While all reasonable efforts are made to ensure that the technical content of IEC Publications is accurate, IEC cannot be held responsible for the way in which they are used or for any misinterpretation by any end user.
- 4) In order to promote international uniformity, IEC National Committees undertake to apply IEC Publications transparently to the maximum extent possible in their national and regional publications. Any divergence between any IEC Publication and the corresponding national or regional publication shall be clearly indicated in the latter.
- 5) IEC itself does not provide any attestation of conformity. Independent certification bodies provide conformity assessment services and, in some areas, access to IEC marks of conformity. IEC is not responsible for any services carried out by independent certification bodies.
- 6) All users should ensure that they have the latest edition of this publication.
- 7) No liability shall attach to IEC or its directors, employees, servants or agents including individual experts and members of its technical committees and IEC National Committees for any personal injury, property damage or other damage of any nature whatsoever, whether direct or indirect, or for costs (including legal fees) and expenses arising out of the publication, use of, or reliance upon, this IEC Publication or any other IEC Publications.
- 8) Attention is drawn to the Normative references cited in this publication. Use of the referenced publications is indispensable for the correct application of this publication.
- 9) Attention is drawn to the possibility that some of the elements of this IEC Publication may be the subject of patent rights. IEC shall not be held responsible for identifying any or all such patent rights.

IEC TR 61094-10 has been prepared by IEC technical committee 29: Electroacoustics. It is a Technical Report.

The text of this Technical Report is based on the following documents:

Draft	Report on voting
29/1113/DTR	29/1124/RVDTR

Full information on the voting for its approval can be found in the report on voting indicated in the above table.

The language used for the development of this Technical Report is English.

This document was drafted in accordance with ISO/IEC Directives, Part 2, and developed in accordance with ISO/IEC Directives, Part 1 and ISO/IEC Directives, IEC Supplement, available at www.iec.ch/members_experts/refdocs. The main document types developed by IEC are described in greater detail at www.iec.ch/publications.

A list of all parts in the IEC 61094 series, published under the general title *Electroacoustics – Measurement microphones*, can be found on the IEC website.

Future documents in this series will carry the new general title as cited above. Titles of existing documents in this series will be updated at the time of the next edition.

The committee has decided that the contents of this document will remain unchanged until the stability date indicated on the IEC website under webstore.iec.ch in the data related to the specific document. At this date, the document will be

- reconfirmed,
- withdrawn,
- replaced by a revised edition, or
- amended.

IMPORTANT – The "colour inside" logo on the cover page of this document indicates that it contains colours which are considered to be useful for the correct understanding of its contents. Users should therefore print this document using a colour printer.

ELECTROACOUSTICS – MEASUREMENT MICROPHONES –

Part 10: Absolute pressure calibration of microphones at low frequencies using calculable pistonphones

1 Scope

This part of IEC 61094

- is applicable to laboratory standard microphones meeting the requirements of IEC 61094-1 and other types of measurement microphones,
- describes one possible absolute method for determining the complex pressure sensitivity, based on a device capable of generating a known sound pressure, especially at low frequencies, and
- provides a reproducible and accurate basis for the measurement of sound pressure at low frequencies.

All quantities are expressed in SI units.

2 Normative references

The following documents are referred to in the text in such a way that some or all of their content constitutes requirements of this document. For dated references, only the edition cited applies. For undated references, the latest edition of the referenced document (including any amendments) applies.

IEC 61094-1:2000, *Measurement microphones – Part 1: Specifications for laboratory standard microphones*

IEC 61094-2:2009, *Electroacoustics – Measurement microphones – Part 2: Primary method for pressure calibration of laboratory standard microphones by the reciprocity technique*
IEC 61094-2:2009/AMD1:2022

3 Terms and definitions

For the purposes of this document, the terms and definitions given in IEC 61094-1 and IEC 61094-2 and the following apply.

ISO and IEC maintain terminology databases for use in standardization at the following addresses:

- IEC Electropedia: available at <https://www.electropedia.org/>
- ISO Online browsing platform: available at <https://www.iso.org/obp>

3.1

pistonphone

device in which sound pressure is generated in a fixed sealed volume of air, by the motion of one or more pistons creating a well-defined volume velocity

3.2

calculable pistonphone

pistonphone where the generated sound pressure can be calculated from physical principles

4 Reference environmental conditions

The reference environmental conditions are the following:

- temperature 23,0 °C;
- static pressure 101,325 kPa;
- relative humidity 50 %.

5 Principles of absolute pressure calibration of microphones using a calculable pistonphone

5.1 General principle

The microphone to be calibrated is exposed to a known or calculable sound pressure produced within the sealed cavity (or coupler) of a pistonphone, without the need for a prior measurement with another microphone. The dimensions of the cavity are constrained to allow the assumption to be made that the sound pressure is uniformly distributed within.

A sound generator consisting of a sealed cavity (or coupler) of known volume that is driven by a piston or similar mechanism capable of producing a known volume velocity (e.g. an electrodynamic loudspeaker) has the potential to generate a known sound pressure. If the piston is assumed to be rigid and of known frontal area, laser interferometry or other displacement measurement techniques can be used to determine the piston displacement and thereby derive the volume displacement.

The pressure sensitivity M_p of the microphone is then determined directly from its open-circuit output voltage $U_{m,0}$ and the applied sound pressure p_m .

$$M_p = \frac{U_{m,0}}{p_m} \quad (1)$$

Alternatively, a microphone system comprising of a microphone, a preamplifier and optionally and amplifier stage, can be calibrated by the same principle, except that the system output voltage replaces the open-circuit output voltage of the microphone in Formula (1).

5.2 Basic expressions

The generated sound pressure p_m that is applied to the diaphragm of the microphone is calculated from an evaluation of the acoustic transfer impedance Z_T of the cavity and a measurement of the piston displacement δx .

The acoustic transfer impedance is the constant of proportionality between the sound pressure at the microphone diaphragm and the volume velocity driving the cavity. In the case of a sinusoidally driven rigid piston, the volume velocity is given by the product of the piston area S_p , the piston displacement and a factor $j\omega$, where ω is the angular frequency:

$$p_m = j\omega S_p \delta x \cdot Z_T \quad (2)$$

If the piston is not rigid, calculation of the volume velocity requires the surface integral of displacement to be determined, for example with scanning interferometry.

The acoustic transfer impedance can be calculated when the cavity has a simple geometry enabling its volume, V to be determined. When the characteristic cavity dimensions are significantly smaller than the acoustic wavelength, λ (typically when $\sqrt[3]{V} \ll \lambda$), then the sound pressure can be assumed to be uniformly distributed within the cavity. Then, assuming adiabatic compression and expansion of the gas and that the cavity is perfectly sealed, the acoustic impedance of the cavity Z_C is $\kappa P_S / (j\omega V)$, where κ is the ratio of specific heats for air and P_S is the static pressure inside the cavity. From the equivalent circuit in Figure 1, Z_T is then given by:

$$\frac{1}{Z_T} = \frac{1}{Z_C} + \frac{1}{Z_m} = j\omega \left(\frac{V}{\kappa P_S} + \frac{V_{e,m}}{\kappa_r P_{S,r}} \right) \quad (3)$$

where

$V_{e,m}$ is the equivalent volume of microphone to be calibrated;

κ and κ_r are the ratio of the specific heats at measurement conditions and at reference conditions respectively;

$P_{S,r}$ is the reference static pressure.

Values for κ and κ_r in humid air can be determined from formulas given in IEC 61094-2:2009, Annex F.

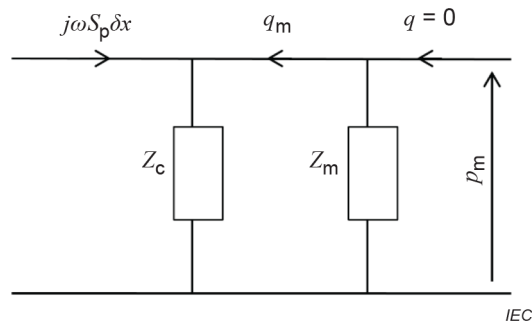

Key

ω angular frequency

S_p piston surface area

δx piston displacement

q and q_m volume velocities

Z_c and Z_m acoustic impedances of the cavity and microphone respectively

p_m sound pressure acting on the microphone

Figure 1 – Equivalent circuit for evaluating the sound pressure over the exposed surface of the diaphragm of the microphone

At higher frequencies, where the wavelength can no longer be considered sufficiently large compared to the cavity dimensions, the evaluation of Z_T generally becomes more complicated and requires the specific geometry of the cavity to be accounted for. The onset of such behaviour is generally considered to be the upper frequency limit for the operation of the pistonphone within the scope of this document.

5.3 Heat conduction correction

The evaluation of Z_T in Formula (3) assumes adiabatic conditions in the cavity. However, in practice, the influence of heat conduction at the walls of the cavity causes increasing departure from purely adiabatic conditions as the frequency is reduced, especially for small cavities.

At frequencies where the sound pressure can be considered to be uniformly distributed within the cavity and under the assumption that the walls remain at a constant temperature, the influence of the heat conduction losses can be calculated and expressed in terms of a complex correction factor ΔH to the geometrical volume V in Formula (3). The formulation for the influence of the heat conduction losses and expressions for a correction factor ΔH , when the cavity shape is a perfect right circular cylinder, are given in IEC 61094-2:2009 and IEC 61094-2:2009/AMD1:2022.

5.4 Operating frequency range

The upper frequency limit of operation is likely to be determined by the onset of sound pressure non-uniformity. This is normally assessed by modelling the sound field within the pistonphone cavity. The model can be used to determine a correction to account for the non-uniform sound pressure distribution for the specific cavity geometry, but a point will be reached where the magnitude of this correction, and therefore the associated uncertainty, becomes unacceptable. Each cavity geometry will require individual treatment, but an upper frequency limit of around 200 Hz is typically possible when characteristic dimensions are no greater than 60 mm.

It is also possible that the volume velocity source determines the upper frequency of operation. As the frequency increases, a greater amount of force is necessary to drive the piston. The frequency at which this capability is exceeded could also set a practical operational limit.

The low frequency limit can be governed by the uncertainty associated with the heat conduction correction, or by pressure leakage from the cavity. The limits that can be achieved are strongly related to the specific design of the pistonphone but there are reports of devices operating at frequencies of 0,01 Hz [1] [2]¹.

6 General characteristics

6.1 The pistonphone

A convenient pistonphone cavity geometry is a right circular cylinder as this allow direct application of the heat conduction model presented in IEC 61094-2:2009 and IEC 61094-2:2009/AMD1:2022.

The estimation of the sound pressure generated within the pistonphone is strongly dependent on the internal volume. When the cavity and the volume velocity source are made from a hard, dimensionally stable, non-porous materials, the influences of time, temperature, humidity and other physical parameters can be expected to have no adverse effect on performance.

Since the pistonphone is typically activated by a vibrating mechanism, care can be needed to ensure the microphone under test is not subjected to extraneous vibration signals capable of contributing to the measured output voltage.

There are no constraints on the size of the cavity, but note that the generated sound pressure is proportional to the ratio of the induced volume velocity to the overall volume of the cavity. Therefore, a larger cavity requires a more powerful volume velocity source.

¹ Numbers in square brackets refer to the Bibliography.

Conversely, the effects of heat conduction generally become less significant at a given frequency as the size of the cavity increases. Heat conduction effects can also be minimised for a given cavity volume, with a dimensional aspect ratio (length-to-diameter ratio for a cylindrical cavity) close to unity.

A unit aspect ratio also maximises the upper frequency limit of operation for a given volume, when the limit is dictated by the onset of sound pressure non-uniformity within the cavity.

Example pistonphone designs can be found in Annex A.

6.2 Measuring the piston volume velocity

If the piston is assumed to be rigid, a technique based on laser interferometry (for example see ISO 16063-11) or other displacement measurement techniques can be used to determine the piston displacement and derive the volume displacement when the piston area is known.

6.3 Test signals

Calibration can be achieved with sinusoidal or broadband stimuli where the signals within frequency bands or at discrete frequencies can be extracted.

6.4 Mounting the microphone and pressure-equalizing tube

The normal construction of a laboratory standard or working standard microphone has the cavity behind the diaphragm fitted with a narrow pressure-equalization tube to permit the static pressure to be the same on both sides of the diaphragm. Consequently, at very low frequencies, this tube also partially equalizes the sound pressure. During the calibration, if sound which is coherent with that acting on the diaphragm also reaches the pressure-equalizing tube, the sensitivity will be altered as a result. This tendency increases as the frequency is reduced. Therefore, the configuration of the pressure-equalizing tube during a calibration strongly influences the frequency response obtained for the microphone under test.

Given this dependency, there are advantages in the pistonphone being capable of coupling the microphone in different ways. For example, some applications can require the microphone sensitivity to be determined with the pressure-equalization tube completely within the sound field (pseudo-free-field response) while others might require the pressure-equalization tube to be isolated from the sound field (pressure-field response).

6.5 Measuring the output voltages of the microphones

The open-circuit output voltage of the microphone can be determined with the insert voltage technique (for example, see IEC 61094-2:2009, 5.3) or by using a measuring system consisting of a high input impedance microphone preamplifier and a voltmeter (for example, see IEC 61094-5:2016, Annex C).

7 Factors influencing the pressure sensitivity

7.1 General

The pressure sensitivity of a microphone under test can depend on several external factors depending on the transduction mechanism of the microphone. The following parameters are considerations for laboratory standard microphones operating on an electrostatic principle with an externally applied polarizing voltage, and other measurement microphones operating in a similar way.

7.2 Polarizing voltage

The basic mode of operation of a polarized condenser microphone assumes a constant electrical charge on the microphone. The product of the microphone capacitance, and the electrical resistance through which the polarizing voltage is applied, determines the time constant for charging the microphone. At sufficiently high frequency (typically above 2 Hz), the time constant is much longer than the acoustic period, and the constant charge condition can be maintained. However, a constant charge cannot be maintained at very low frequencies. While the open-circuit sensitivity of the microphone, as obtained using the insert-voltage technique, will be determined correctly, the absolute output from the preamplifier associated with the microphone will decrease at low frequencies in accordance with this time constant.

The sensitivity of a laboratory standard or working standard microphone is approximately proportional to the polarizing voltage.

7.3 Shield configuration

The open-circuit voltage, and therefore the pressure sensitivity, depends on the shield configuration. IEC 61094-1 describes a reference mechanical configuration for the shield that can be used in determining the open-circuit voltage. While the reference mechanical configuration is described, the shield can either be grounded (grounded-shield configuration), or the output voltage from the microphone can be applied to the shield (driven-shield configuration). The configuration used in practice can influence the results achieved.

The manufacturer can also specify a maximum mechanical force to be applied to the central electrical contact of the microphone.

7.4 Dependence on environmental conditions

7.4.1 General

The sensitivity of a microphone can depend on static pressure, temperature, or humidity. The actual conditions during the calibration are normally reported.

7.4.2 Static pressure

Within the microphone, the acoustic resistance and mass of the gas between the diaphragm and backplate, the compliance of the cavity behind the diaphragm and thus the pressure sensitivity of the microphone itself, depend on the static pressure. This dependence is a function of frequency.

For information on the influence of static pressure on the pressure sensitivity of laboratory standard condenser microphones, see for example IEC 61094-2:2009, Annex D.

In addition, the sound pressure generated by the pistonphone is directly proportional to the prevailing static pressure within the pistonphone.

7.4.3 Temperature

Within the microphone, the acoustic resistance and mass of the gas between diaphragm and backplate and thus the pressure sensitivity of the microphone itself, depend on the temperature. In addition, the mechanical dimensions of the microphone depend on the temperature and the sensitivity of the microphone depends on the mechanical tension in the diaphragm and on the spacing between diaphragm and backplate. The total effect of these dependencies is a function of frequency.

For information on the influence of temperature on the pressure sensitivity of laboratory standard condenser microphones, see for example IEC 61094-2:2009, Annex D.

7.4.4 Humidity

Although the thermodynamic state of the air enclosed in the cavity behind the diaphragm of the microphone depends slightly on humidity, an influence on the sensitivity has not been observed for laboratory standard microphones, provided condensation does not take place.

7.5 Vibration

Vibration of the microphone housing can result in an output signal. Since the pistonphone has an integrated vibration source, there is potential for a coherent but non-acoustic excitation of the microphone.

7.6 Distortion

The mechanical motion of the volume velocity source can be impacted by friction and electromagnetic effects, which can cause the motion to become distorted (i.e. non-sinusoidal). It is therefore essential to measure the displacement and the microphone output voltage on a comparable basis. In particular, when applying an insert-voltage method using a high-quality signal generator to produce the (undistorted) insert voltage, it is good practice to match the peak rather than the RMS voltages when calculating the microphone sensitivity.

8 Calibration uncertainty components

8.1 General

In addition to the factors mentioned in Clause 7 which affect the pressure sensitivity, further uncertainty components are introduced by the method, the equipment, and the degree of care under which the calibration is carried out. With due care, the factors affecting the calibration in a known way can be managed to minimize their influence on the resulting measurement uncertainty.

8.2 Measurements of microphone output voltage

Uncertainties of random or time-varying nature and of a systematic nature, in the measurement of the microphone output voltage, directly affect the uncertainty in the pressure sensitivity.

Noise or other interference such as cross-talk, whether of acoustical or other origin, can typically be managed so as to not unduly affect the determination of the pressure sensitivity.

The stability of the measurement system and its linearity has an associated uncertainty.

8.3 Piston

8.3.1 Frequency

The frequency at which the piston is driven by a function generator has an associated uncertainty.

8.3.2 Measurement of the volume velocity

Uncertainties of random, time-varying nature and of a systematic nature in the measurement of the volume velocity of the piston directly affect the uncertainty in the pressure sensitivity of the microphone.

The calculated sound pressure is directly proportional to the volume velocity of the piston.

If the piston is assumed to be rigid and the displacement is then measured at a single point, allowances can be made for any departure from this assumption, for example a loudspeaker can exhibit flexure in its driven surface, and the displacement of its suspension mechanism can be different.

If a scanning technique is used to measure the displacement at several points, the uncertainty in the surface integration algorithm contributes an uncertainty component.

8.4 Acoustic transfer impedance

8.4.1 Cavity properties

It is generally possible that the shape and dimensions of the pistonphone cavity can be chosen such that the sound pressure can be calculated as described in 5.2. As long as the greatest dimension of the cavity is small compared to the wavelength of sound in the gas, the sound pressure will be substantially uniform in the cavity.

The uncertainty on cavity dimensions affects the acoustic transfer impedance by different amounts that vary with frequency. It also influences the heat conduction. The formulation provided in IEC 61094-2:2009 and IEC 61094-2:2009/AMD1:2022 for the influence of the heat conduction losses is valid for a perfect cylinder.

With due care, it is possible to avoid leakage in the cavity, which affects the acoustic transfer impedance. Leakage can be assessed by observing the decay of a step displacement input to the cavity. Alternatively, a capillary tube can be used as a controlled leakage, such that the resulting acoustic transfer impedance can be calculated. Whether controlled or uncontrolled, the measurement uncertainty component arising from leakage can establish a practical low-frequency limit of operation of the pistonphone.

8.4.2 Physical quantities

The acoustic transfer impedance depends on certain physical quantities describing the properties of the gas enclosed in the cavity. These quantities depend on environmental conditions such as static pressure, temperature, and humidity. For values of the quantities for humid air and their dependence on environmental conditions, see for example IEC 61094-2:2009, Annex F.

The resulting uncertainty on the calculated quantities is a combination of the uncertainty on the equations and the uncertainty on the measurement of the environmental conditions.

8.5 Microphone parameters

8.5.1 Front cavity

A laboratory standard microphone has a recessed cavity in front of the diaphragm.

In Formula (3), the volume of the microphone front cavity together with the equivalent volume of the microphone (see 8.5.2) forms a part of the total volume V of the pistonphone cavity. Therefore, uncertainty in these parameters contributes to the overall volume uncertainty.

8.5.2 Acoustic impedance

The acoustic impedance of the microphone is a function of frequency, and is determined mainly by the properties of the stretched diaphragm and the air enclosed in the cavity behind the diaphragm, and by the geometry of the backplate. To a first approximation, the acoustic impedance can be expressed in terms of equivalent series-connected compliance, mass and resistance. This network can alternatively be described by compliance, resonance frequency and loss factor. Compliance is often given in terms of the low frequency value of the real part of the equivalent volume of the microphone (for example, see IEC 61094-1:2000, 6.2.2).

At very low frequencies, the pressure-equalizing tube of the microphone affects its acoustic impedance, and heat conduction in the cavity behind the diaphragm results in an increase of the equivalent volume. The acoustic impedance Z_m of the microphone can form a non-negligible part of the acoustic transfer impedance Z_T of the system.

Methods that can be used for determining the acoustic impedance are described in IEC 61094-2:2009, Annex E.

8.5.3 Polarizing voltage

When determining the polarizing voltage, provision can be made for measuring this directly at the terminals of the microphone. This is important when the polarizing voltage is obtained from a high-impedance source, due to the finite insulation resistance of the microphone. Alternatively, the insulation resistance of the microphone can be measured and verified to be sufficiently high that a measurement of the polarizing voltage supply with the microphone removed, or a measurement at a low impedance port of the polarizing voltage supply, are valid.

8.6 Uncertainty on pressure sensitivity level

The uncertainty on the pressure sensitivity level can be determined in accordance with ISO/IEC Guide 98-3. When reporting the results of a calibration the uncertainty, as function of frequency, the expanded uncertainty of measurement using a coverage factor of $k = 2$, is normally stated.

Due to the co-dependence of the factors in the final expression for the pressure sensitivity in Formula (2) on certain of the external influences (e.g. environmental dependencies), the uncertainty analysis of the acoustic transfer impedance is usually performed by repeating a calculation while the various components are changed one-at-a-time by their associated uncertainty. The difference in the result derived by the unchanged components is then used to determine the standard uncertainty related to each component.

Table 1 lists components affecting the uncertainty of a calibration. Not all of the components are necessarily relevant in a given design of pistonphone or calibration setup, because various methods can be used for measuring the applied volume velocity and microphone output voltage, and for determining the microphone parameters.

Table 1 – Uncertainty components

Measured quantity	Relevant subclause no.
Measurements of microphone output	
Voltage measurements	8.2
Cross-talk	8.2
Inherent and ambient noise	8.2
Ground shield	7.3
Piston	
Frequency	8.3.1
Measurement of the volume velocity	8.3.2
Cavity properties	
Cavity volume	8.4.1
Cavity shape and heat conduction theory	8.4.1
Unintentional leakage	8.4.1
Capillary tube dimensions	8.4.1
Static pressure	8.4.2

Measured quantity	Relevant subclause no.
Temperature	8.4.2
Relative humidity	8.4.2
Microphone parameters	
Front cavity volume	8.5.1
Equivalent volume	8.5.2
Polarizing voltage	8.5.3
Processing of results	
Rounding error	
Repeatability of measurements	
Static pressure corrections	7.4.2
Temperature corrections	7.4.3

The uncertainty components listed in Table 1 are generally a function of frequency and are quantified as a standard uncertainty. The uncertainty components are expressed in a linear form, but a logarithmic form can be used, as the values are very small and the derived final expanded uncertainty of measurement would be essentially the same.

It is estimated that a calibration of a laboratory standard microphone can achieve an overall expanded uncertainty with a coverage factor $k = 2$ of approximately 0,05 dB at upper frequencies (2 Hz to 20 Hz), increasing to approximately 0,2 dB at the lowest frequencies (around 0,01 Hz). An example of uncertainty calculation is provided in Annex B.

Annex A (informative)

Example designs of pistonphones using laser interferometry

Figure A.1 to Figure A.3 show example designs of pistonphones using laser interferometry.

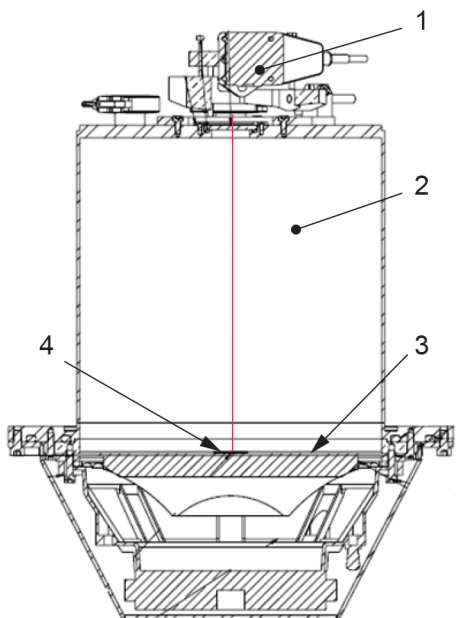

IEC

Key

- 1 interferometer
- 2 sealed cylindrical cavity
- 3 rigid circular piston (based on a modified loudspeaker)
- 4 mirror

Figure A.1 – Schematic cross-section of a laser pistonphone

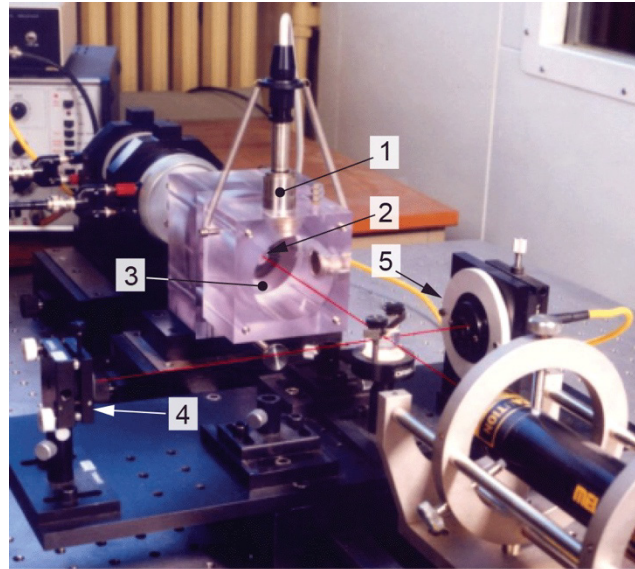
**Key**

- 1 microphone under test
- 2 piston
- 3 cavity
- 4 fixed mirror
- 5 optical detector and fibre

NOTE The end face is removed to reveal the inside of the cavity and piston, for illustration purposes.

Figure A.2 – Example of laser pistonphone



NOTE The device under test is a microbarometer rather than a measurement microphone, illustrating the versatility of a suitably designed laser pistonphone as calibration device.

Figure A.3 – Example of laser pistonphone

Annex B (informative)

Measurement uncertainties

B.1 General

All uncertainties of measurements can be calculated in accordance with the guidelines given in ISO/IEC Guide 98-3 (GUM), and typically quantified for a coverage probability of 95 %.

The components of measurement uncertainty considered below relate to general requirement of microphone sensitivity calibration. It is possible some components are not relevant, or additional components need to be considered, in specific implementations.

B.2 Example of a typical uncertainty analysis

B.2.1 General

Table B.1 is an example of how the measurement uncertainties would be calculated for the sensitivity magnitude of a generic measurement microphone. This is not an exhaustive list of possible measurement uncertainty components, or even a guide to typical values (as the values chosen for illustration only, in this example), but just an example of the calculation method required by the GUM.

For this example, figures are just given for one frequency (1 Hz); in practice, the calculation is typically repeated for each frequency used. The reported measurement uncertainty is based on a standard uncertainty multiplied by a coverage factor $k = 2$, providing a level of confidence of approximately 95 %.

B.2.2 Uncertainty budget

The measurement uncertainty arises from twenty different sources, but it is possible additional components are relevant in a particular practical implementation. It is assumed that the sensitivity of the microphone under test is linearly dependent on each of the identified components.

Table B.1 – Example of uncertainty budget at 1 Hz

Measured quantity		Standard uncertainty
		in dB × 1 000
Measurements of microphone output voltage	Voltage measurements	5,8
	Cross-talk	0,5
	Inherent and ambient noise	5,0
	Ground shield	0,5
Piston dynamics	Frequency	2,6
	Measurement of the volume velocity	12,9
Cavity properties	Cavity volume	6,9
	Cavity shape and heat conduction theory	1,0
	Unintentional leakage	0,0
	Capillary tube dimensions	0,0
	Static pressure	2,2
	Temperature	0,1
	Relative humidity	0,1
Microphone parameters	Front cavity volume	0,0
	Equivalent volume	0,0
	Polarizing voltage	2,5
Processing of results	Rounding error	2,9
	Repeatability of measurements	5,6
	Static pressure corrections	0,1
	Temperature corrections	0,1

B.2.3 Combined and expanded uncertainties

The combined standard measurement uncertainty is found from the square root of the sum of the squares of each standard uncertainty component given in Table B.1, giving 0,02 dB (a strict calculation would require each component to be converted from logarithmic to linear form before doing the combination but as the values are very small, the result would be essentially the same). The expanded measurement uncertainty with a coverage factor of 2 is then 0,04 dB.

Bibliography

- [1] Vincent P., *Development of a sound pressure primary standard and an associated reference calibration method for the calibration of infrasound sensors at 1 Hz. Thesis report, Université du Mans, 2018*
 - [2] W. He, L.B. He, F. Zhang, et al., *A dedicated pistonphone for absolute calibration of infrasound sensors at very low frequencies, Meas. Sci. Technol. 27 (2) (2016) 025018*
 - [3] IEC 61094-5:2016, *Electroacoustics – Measurement microphones – Part 5: Methods for pressure calibration of working standard microphones by comparison*
 - [4] ISO/IEC Guide 98-3, *Uncertainty of measurement – Part 3: Guide to the expression of uncertainty in measurement (GUM:1995)*
 - [5] ISO 16063-11:1999, *Methods for the calibration of vibration and shock transducers – Part 11: Primary vibration calibration by laser interferometry*
 - [6] A.J. Rennie, *A laser-pistonphone for absolute calibration of laboratory standard microphones in the frequency range 0.1 Hz to 100 Hz, NPL Acoustics Report Ac. 82 (1977)*
 - [7] Barham R. and Goldsmith M., *The application of the NPL laser pistonphone to the international comparison of measurement microphones. Metrologia, 44(3):210, 2007. 14, 21, 50*
 - [8] Barham R. G 1994, *The NPL laser pistonphone. J. Low Freq. Noise Vib., 12, p. 36-38*
 - [9] Di Liu, Aibing Liu, Fan Zhang, Xianyue Gang, Lijun Li, Haizhi Wu, *A dynamic pressure calibration device based on the low speed servomotor and pistonphone technique, Measurement 151 (2020)*
-

INTERNATIONAL
ELECTROTECHNICAL
COMMISSION

3, rue de Varembé
PO Box 131
CH-1211 Geneva 20
Switzerland

Tel: + 41 22 919 02 11
info@iec.ch
www.iec.ch